

CUBE HOPPER MK II

Instruction-Service Manual

Model 10-1700

Version2.4/June 1999

A New Design to solve most of your payout problems!

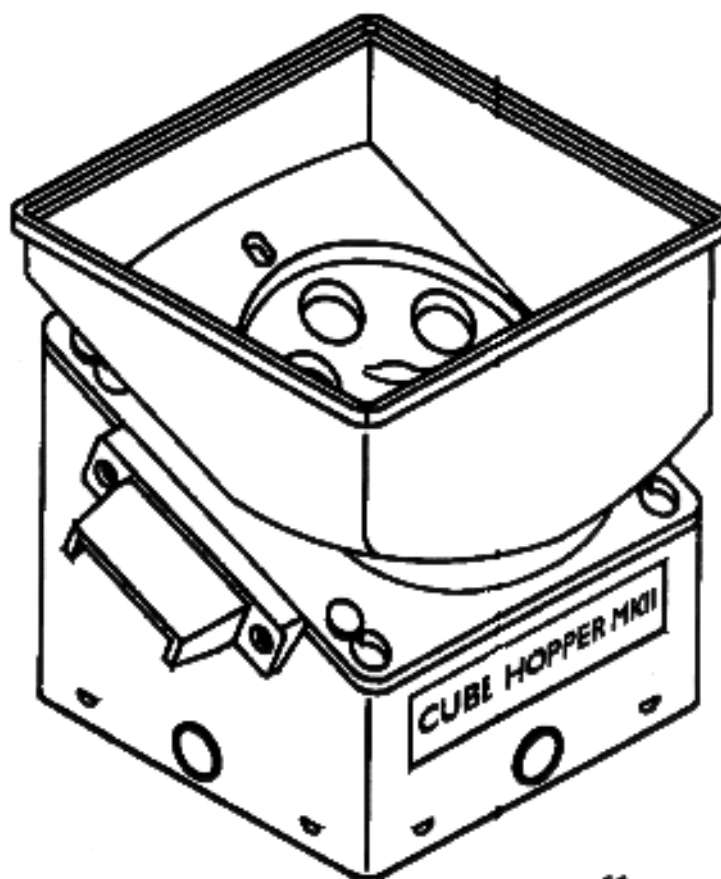

CE Approved

REFERENCE CHART:

Model no.10-1700-20 for diameter 19/22mm and 1.5 to 2mm thick coins.

Disc **A** has a red coloured spot (Part no.10-0240-2).

Use coin inert plate A (Part no10-0238)

Model no.10-700-30 for diameter 19/22mm and 2.1 to 3.2mm thick coins.

Disc **AA** has an orange coloured spot (Part no.10-0240-3) use together with anti-surfkit10-0017.

Use coin insert plate A (Part no.10-0238)

Model no.10-1700-40 for diameter 22.1/23,8mm and 1,5 to 2mm thick coins.

Disc **B** has yellow coloured spot (Part no. 10-0240-4).

Use coin insert plate B1(Part no.10-0238-1)

Model no. 10-1700-41 for diameter 23,9/25,5mm and 1,5 to 2mm thick coins

Disc **B** has a yellow coloured spot (Part no.10-0240-4).

Use coin insert plate B2 (Part no. 10-0238-2)

Model no. 10-1700-50 for diameter 22,1/23,8mm and 2.1 to 3,2mm thick coins.

Disc **BB** has a green coloured spot (Part no.10-0240-5) use together with anti-surfkit 10-0017.

Use coin insert plate B1 (Part no.10-0238-1)

Model no.10-1700-51 for diameter 23,9/25,5mm and 2.1 to 3,2mm thick coins.

Disc **BB** has a green coloured spot (Part no.10-0240-5) use together with anti-surfkit 10-0017.

Use coin insert plate B2 (Part no.10-0238-2)

Model no.10-1700-60 for diameter 25,6/27,8mm and 1,5 to 2mm thick coins.

Disc **C** has a blue coloured spot (Part no.10-0240-6).

Use coin insert plate C1 (Part no.10-0238-3)

Model no.10-1700-61 for diameter 27,9-30mm and 1,5 to 2mm thick coins.

Disc **C** has a blue cooured spot (Part no. 10-0240-6).

Use coin insert plate C2 (Part no.10-0238-4)

Model no.10-1700-70 for diameter 25,6/27,8mm and 2.1 to 3.2mm thick coins.

Disc **CC** has a pink coloured spot (Part no.10-0240-7).

Use coin insert plate C1 (Part no.10-0238-3)

Model no.10-1700-71 for diameter 27,9/30mm and 2.1. to 3.2mm thick coins.

Disc **CC** has a pink coloured spot (Part no.10-0240-7).

Use coin insert plate C2 (Part no.10-0238-4)

Model no. 10-1700-80 for diameter 30,1/31mm and 1,5 to 2mm thick coins.

Disc **D** has a black coloured spot (Part no. 10-0240-8).

Use coin insert plate D1 (Part no. 10-0238-5)

Model no.10-1700-81 for diameter 30,1/31mm and 2,1 to 3,2mm thick coins.

Disc **DD** has a black coloured spot (Part no.10-0240-9).

Use coin insert plate D1(Part no.10-0238-5)

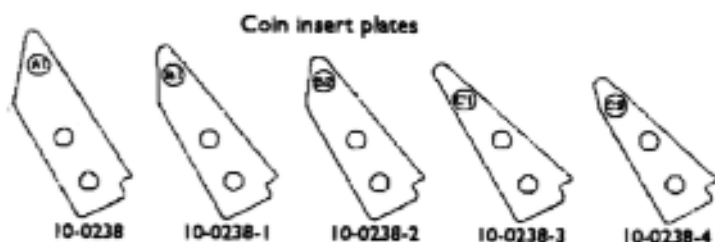

Payout discs

Disc	Colour spot	Part no.
A:	Red	10-0240-2
AA:	Orange	10-0240-3*
B:	Yellow	10-0240-4
BB:	Green	10-0240-5*
C:	Blue	10-0240-6
CC:	Pink	10-0240-7
D:	Black	10-0240-8
DD:	Black	10-0240-9

use anti-surfkit 10-0017

Coin insert plates

Plate	Coin o diam	Part no.
A1	19/22mm	10-0238
B1	22,1/23,8mm	10-0238-1
B2	23,9/25,5mm	10-0238-2
C1	25,6/27,8mm	10-0238-3
C2	27,9/30mm	10-0238-4
D1	30,1/31mm	10-0238-5

Congratulations on your purchase of this **CUBE HOPPER MKII** and thank you for having confidence in our our quality products

Instruction Manual

Standard hopper for different applications



SaXXot Deutschland GesmbH.
81669 München Zeppelinstrasse 73
Tel +49 (0)894141446-00 Fax. DW 75
<http://www.saXXot.de> E-mail: verkauf@saXXot.de

This **CUBE HOPPER** is a single coin payout system made universal for all round coins between 19 to 31mm with a thickness of 1,5 to 3,2mm by using the relevant payout disc and coin insert plate.(See Reference Chart)

Features

The hopper is square and easy to mount by means of a standard mounting-bracket(included). By using an unique“sun and planet“ gearbox system this Hopper offers the possibility to contain and count (with two extensions) over 1200 coins....of ϕ 24mm.

The Hopper is protected by an autoreverse anti-jam system and has an indirect optical readout. A low level sensing detection is integrated in the coin cup and can be connected to the connector at pin 1 and 2.

When using the correct pin on the connector the Hopper operates on safe voltage (12 or 24 VDC).

Power consumption: 400mA to 850mA-2Amp peak.

It is easy to change to any coin between 19 and 31mm within the thickness range from 1,5 to 3,2mm, just fit the correct payout disc and coin insert plate on the platform.

Note“ By using small thick coins 19-25,5 diameter and 2,1-3,2mm the use of anti-surfkit is advised“ art.nr 10-0017

How to remove the disc?

Slide the red button on the back to“Down“ position, remove the coin by sliding it in “Up“ position and remove the disc from the platform.

Before bringing the new disc onto the platform, please check:

a) That the correct coin insert plate is mounted on the platform under the bridge.(See Reference Chart)

b) Place the new disc on the platform after fitting the correct coin insert plate.
(**Don't forget to put the black Telfon bearing in the centre of the platform**)

c) Bring the coin cup onto the platform and slide the red button in up position!

Look at Part no: 10-1700-(XX) on the sticker at the backside of the hopper.

Disc marked X= red A(20) or orange AA (30)-yellow B(40) or (41)-green BB (50) or (51) blue C (60) or (61)-pink CC (70) or (71) black D (80) or DD(81) (See Reference Chart)

Service Manual

Electrical features

When a coin appears at the Countner Pawl under the Exit Bridge the PCB controls the coin verification and releases a logic signal.The Opto Coupler and the Countner Pawl detect paid-out coins.

The hopper stops by "POWER OFF" from the host machine.
And electronic overload detection system protects the motor and in case of a coin jam it will temporarily turn the hopper disc several times in the opposite direction until the jam is solved if not the hopper switches itself off.

1.1. Coin capacity

The average capacity of the standard **CUBE HOPPER** is approximately 500 coins (diameter 24mm, thickness 2mm). An available option is extension that enlarges the capacity to around 850 coins with the same thickness and diameter as above.

1.2. Payout direction (4-sides)

Because of its unique square design the **CUBE HOPPER** can be mounted in 4 ways. The mounting bracket can be placed in any convenient direction for easy access to the red release button.

Service Manual

Removal and installation

2. Removing the Hopper

Power should be shut off until removal is completed. Press the red release button on the mounting plate, remove the connector and the Hopper can easily be removed.

2.1. Installation of the Hopper

First plug the connector into the Hopper at the reverse side and slide it into the two red hooks on the Mounting Bracket then press the red button with lever slightly backwards and push the Hopper onto the Bracket.

2.2. Coin spillage.

It is possible that when the Hopper is working some coins will be thrown out and dropped beside the hopper, as also can happen when using an extension. This can be avoided by using a Coin Entry Cover.

Mechanical description

3 Dis-assembly of the CUBE HOPPER

The coin cup can easily be removed by sliding the button to the lower position and then sliding the coin cup backwards in the direction of the red slide. You now have access to the disc and the Coin Exit Bridge to change and these components.

3.1. Functions of individual parts

The motor is controlled by the PCB and operates the disc by means of gears and shafts. The gearbox is constructed according to the sun and planet system.

The motor can easily be exchanged by first unplugging the connector from the PCB and then dismounting the motor holder which is connected to the gear box by means of a bayonet catch. Press down the engraved slide on the motor housing and turn the motor housing in an anti-clockwise direction to take it off. Now take a new motor and refit into the motor holder.

The gearbox can also be removed completely by unscrewing the three screws, which attach the gearbox to the platform and removing the rollpin on top of the motor shaft. The Counter Pawl fits an Opto output detector with a transmitter inside the Hopper. The Counter Pawl makes sure that the coin always leaves the Hopper and the construction is done in such a way that once the coin leaves the disc it can never return to the Hopper.

3.2. Coin routing

The coins enter the hopper via the top of the Coin Cup and are ejected sideways via the Coin Exit Bridge.

4 Electrical Interface

The electronics of the Hopper work with 12VDC or 24 VDC.

The 12VDC must be connected by pin 8

The 24VDC must be connected by pin 7.

The Earth wire must be connected by pin 9.

WARNING

Failure to observe the interface requirements specified in this technical manual may result in miscounts, damage to the electronics and the motor of the Hopper or create unacceptable voltage drops, affecting other units depending on that supply.

4.1. Connector

Pin 1 low level

Pin 2 low level connector (common)

Pin 3

Pin 4 Button 12/24VDC for emptying the hopper (optional).

Pin 5

Pin 6 opto-sensor.

Pin 7 24 Volt positive supply and motor control.

Pin 8 12 Volt positive supply and motor control.

Pin 9 Ground common supply.

You can use a 9 pin molex connector (Part no. 22-01-2095) and crimp terminals (Part no. 05-50-0032) or equivalent with a pitch of 0,1" (2,4mm). Note: Be careful with the numbering of the connector as some brands use the numbering upside down. Furthermore all assemblies are connected with JST connector to the main PCB.

4.2. Motor control

Sending and interrupting the positive supply of 12 or 24V DC controls the motor.

The motor is automatically stopped when the supply is disconnected.

Duty cycle 2:1

Routine maintenance

4.3. Coin Counting

Coins per second:7-All paid out coins pass by the Optical Sensor indirectly. The coin exit output changes from a high impedance to a low impedance status.This output stays high as long as the Hopper is the“Off“ STATUS:Rayout signal: open collector NPN-active low Maximum sink of 25mA at 34 Volt maximum.Minimum time obstructs 10mS-minimum.Time between coins-100mS.Payout signal:open collector/active low.

Power supply requirements.

5 Voltage

12 and 24 VDC Nominal (+/-10%).

Maximum ripple voltage +/- 2,4 volts.

absolute maximum 26 volts.

When using 24DVC minimal 17VDC,by using 12VDC minimal 2 VDC.

Swith/reverse current 2 AMP.

5.1. Current consumption.

Current is Zero whilst stopped (Hopper disconnected).

With maximum coin load 850mA average.

Motor start up and reversing surge 2Amp falling to approximately 850mA (Hopper full). ar 400mA (Hopper empty) afer 200mS.

5.2 Temerature.

Storage temperature -20°C to +70°C.

Operating temerature -0°C to+50°C.

Humidity Min.20%-Max 75%

5.3. General.

Ensure that the exit is not blocked so that coins can always move freely.

Maintenance.

IMPORTANT.

Important:shut-off power from the host machine before start cleaning activities.

6. Cleaning and Materials

All reachable places where the coins go must be cleaned every 6 months or 500.000 coins with a moist coth with dry silicon spray (Part no 20-0124-1) In particular the Opto Coupler needs to be klept clean otherwise unreliable coin counthing could occur.

Troubleshooting.

7. Test equipment.

General testing equipment (like multimeter) is all you need on the road to enable you to make a diagnosos of a problem with the **CUBE HOPPER**.

For use in the workshop we sell special test equipment. (part no. 10-0155)

7.1. Coins fall to unjam

- a. Are you using the correct coin insert ? (See Reference list)
- b. Are you using the right disc? (See Reference list)
- c. Be sure Opto Coupler is clear!

d. Are there badly ore incorrect coins in the Hopper?

7.2. Motor falls to run.

- a. Check the Hopper fuse of the host machine.
- b. Protection device tripprd-wait for 30 seconds with the power switched off.

7.3. Over payout of coins.

- a. Check the Opto Coupler for accumulated dirt oe dust.
- b. Check exit monitoring by the host machine.
- c. Disconnecting too late the supply of the power by the host machine after registration of the coin output.

7.4. Under payout of coins.

- a. Make sure the Hopper has sufficient coins.
- b. Incorrect registration by the host machine.
- c. Incorrect exit output debouncing by the host machine.
- d. bad contact with the Hopper.

7.5 No payout signal

- a. Place check coin insert plate, for refernce look at page 2

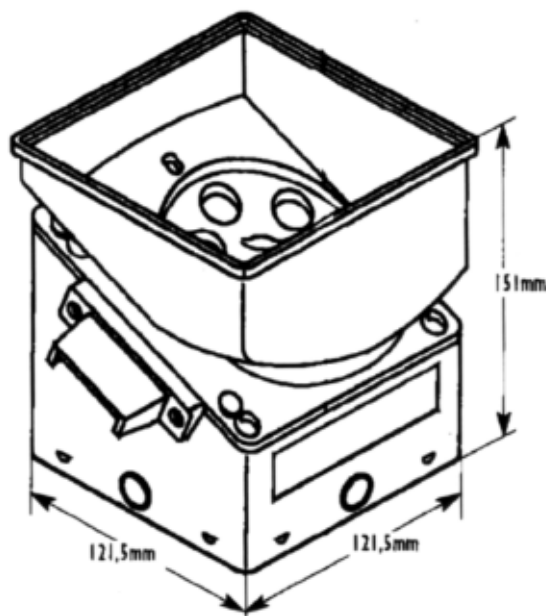

Dimensions

Weight

standard:

D: 12,5mm W:121,5mm H:151mm 780gramm

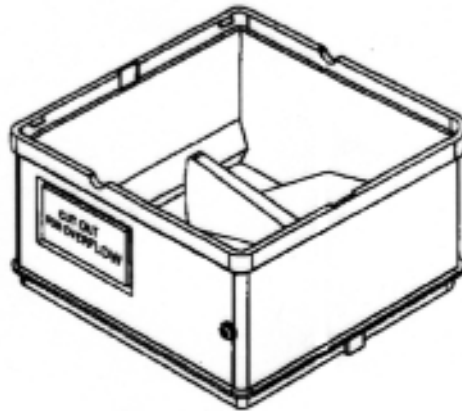

Optional available

o) Extension -Part no 10-0200

; A 64mm high extension together with standard gives a capacity of 850 coins of $\phi 24$ mm.
 Can be used for all coins up to $\phi 29,5$ mm.

;A Second extension is possible for disc **A-AA-B-BB**.
 can be used for a maximum coin size up to $\phi 26$ mm.
 Gives a capacity of 1200 coins of $\phi 24$ mm.

Dimensions

Weight

With one extension:

D: 121,5mm W:121,5mm H:215,5 860gram

With two extensions:

D:121,5mm W:121,5mm H:284mm 940gram

Futher options are:

o) Driver Interface Cable.

If the switching Transistor in the host machine is not powerful enough for driving the CUBE HOPPER?

use our Driver Interface Cable -Part no. 10-0150



o) Service button on backside.

o) And Surf kit (for use with small thick coins)



SaXXot Deutschland GesmbH.
81669 München Zeppelinstrasse 73
Tel +49 (0)894141446-00 Fax. DW 75
<http://www.saXXot.de> E-mail: verkauf@saXXot.de

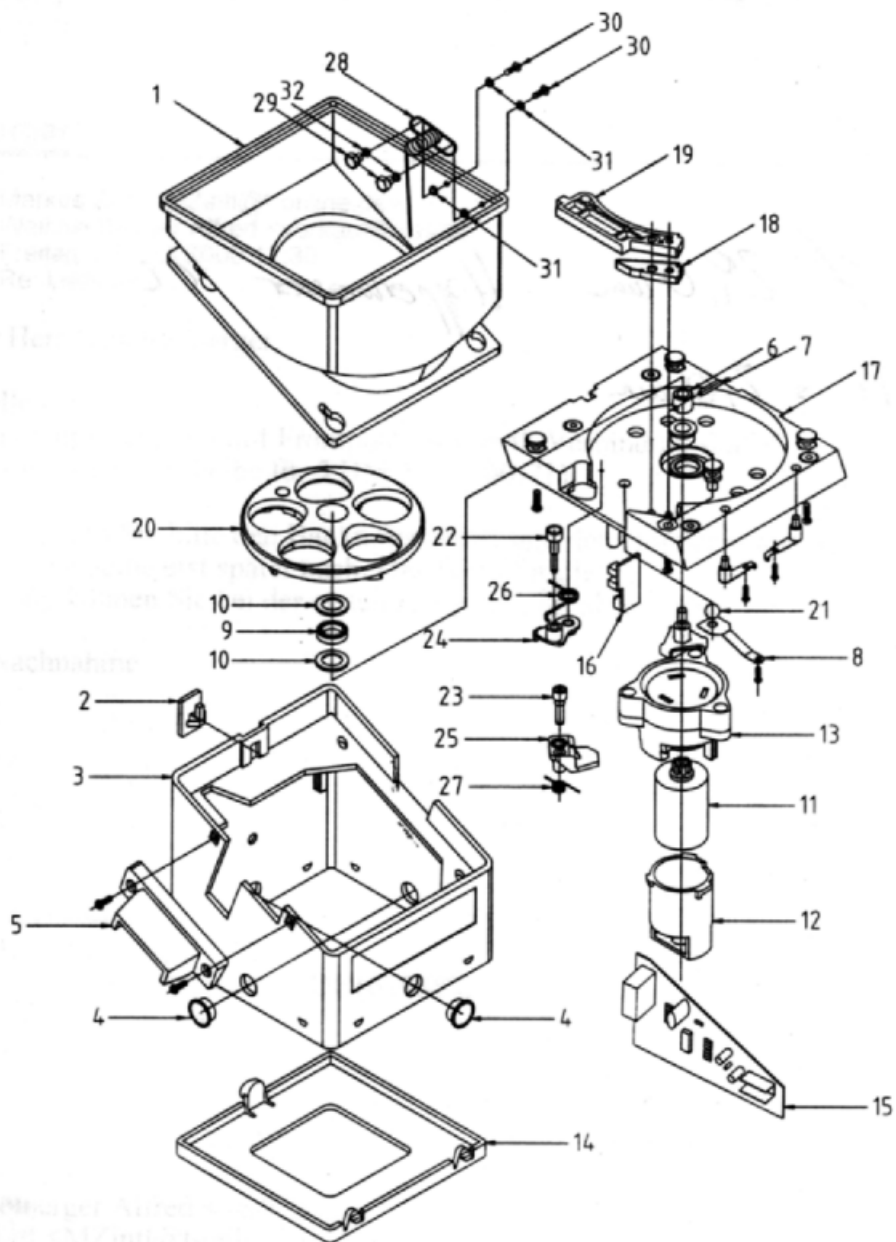



SaXXot Deutschland GesmbH.
81669 München Zeppelinstrasse 73
Tel +49 (0)894141446-00 Fax. DW 75
<http://www.saXXot.de> E-mail: verkauf@saXXot.de

CUBE HOPPER

Registered Desing no:71447-00

CUBE HOPPER MKII SPECIACATIONS

Operating Voltage	12V DC and 24V DC+/-10%
Operating Voltage min.	Pin B:12V DC-pin 7:17V DC
Temperature min.	0°C
Temperature max.	50°C
Duty Cycle	2:1
Humidity min.	20%
Humidity max.	75%
Coins per second	=7
Payout position	4 sides
Max. current not loaded	400mA
Max.current loaded	850mA
Max.current	2A
Connector	9-way connector+pins Type.Molex 22-01-2095+08-50-0032
Payout signal	Open collector-active low 25mA-35V
Coin size	19mm-31mm
Coin thickness	1,5mm-3,2mm
Min.tme between coins	100mS
Min.time obstructs optics	5mS

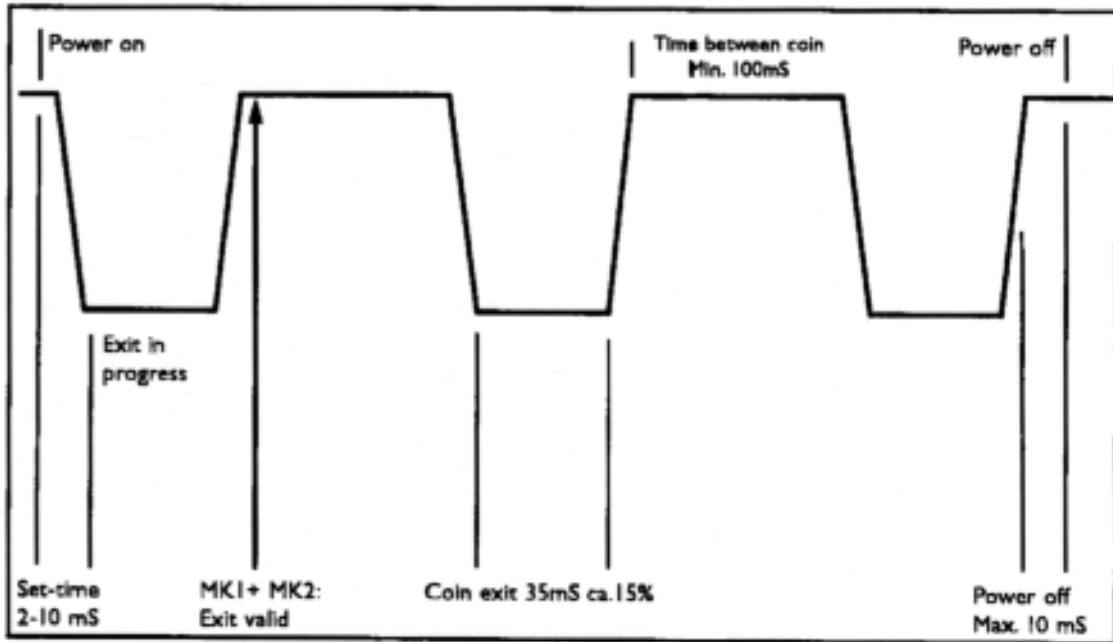

Timing diagram Cube Hopper MK2 type 10-1700

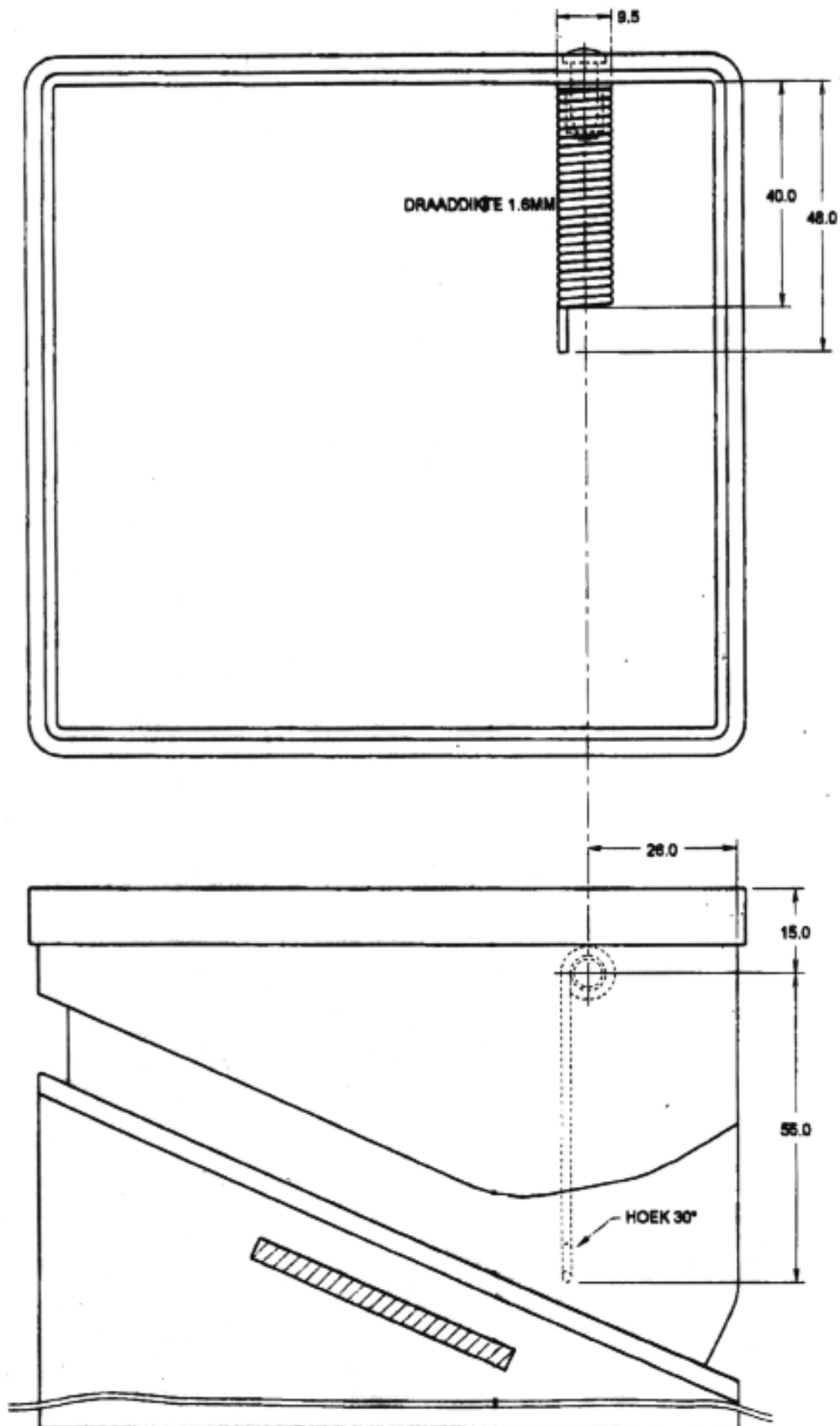

Interfacing the Cube HopperII

The hopper must be connected to the host machine as follows

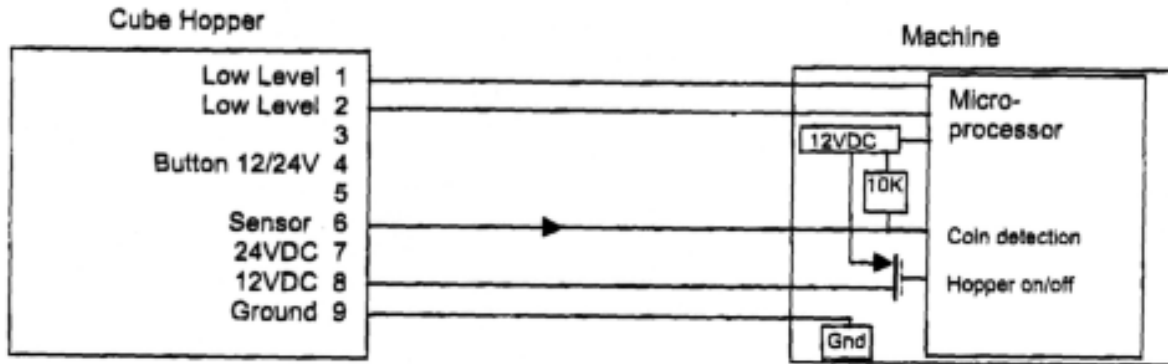

The Low Level pins are connected to 2 copper plates which make contact with each other if there are enough coins in the hopper. The low level signals just act like a switch.

The Sensor signal must be pulled up to 5 or 12V by a resistor of about 10K in the host machine, because the Hopper Sensor output is an open collector type. When power is supplied to the hopper, through a transistor switch, the sensor output remains high and the hopper starts turning. When a coin arrives at the output gate of the hopper, the sensor level goes low. During the coin passing the output gate the sensor signal remains low. When the coin leaves the hopper output gate, the sensor level goes up again.

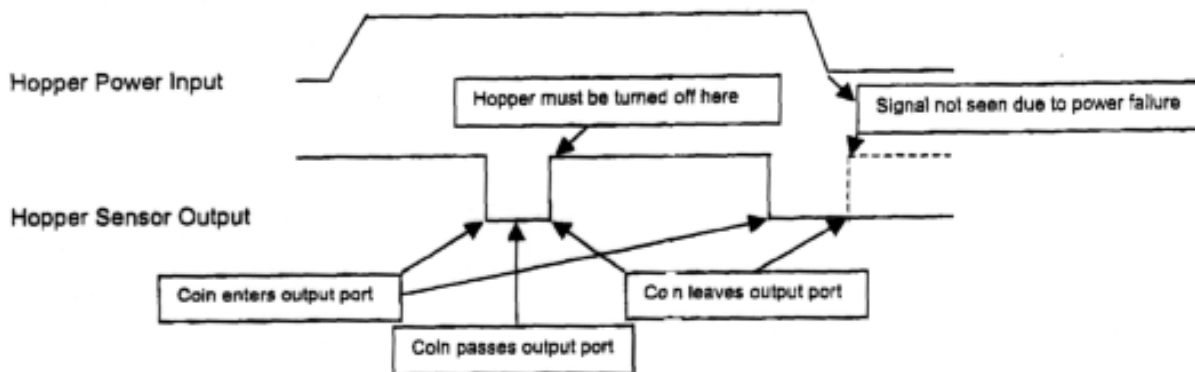

The best way to process the sensor output signal is as follows. When the sensor signal goes low (coin enters output part) the software registers that a coin is paid but does not turn off the hopper yet. Turning off the hopper at this moment stops the hopper immediately and the coin may be stuck in the output port. After the sensor signal goes up again (coin leaves output part) the hopper must be turned off immediately preventing an over payout.

In short: The software must register a coin payout at the falling edge of the sensor signal and turn off the hopper at the rising edge of the sensor signal.

Main Power Down event

If the main power goes down during a payout and the falling edge is detected (coin is registered) it is theoretically possible that the coin is registered but has not left the hopper and still resides in the output port. In this case an underpayout would occur. The software in the machine must check the sensor level after power up again. If the level is low, the hopper must be turned on for a short moment, releasing the coin in the output port. If the level is high, the coin has already left the hopper.

