

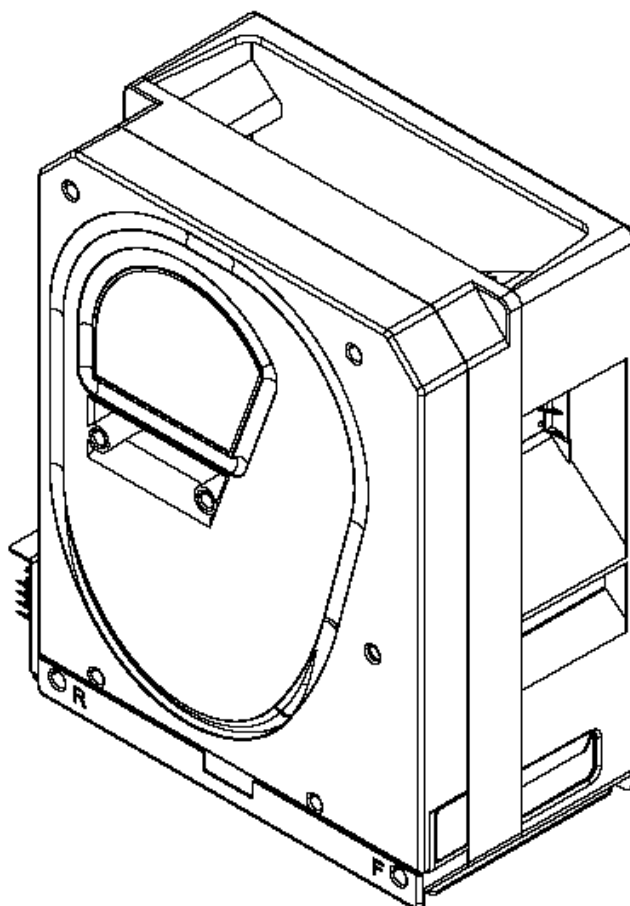

Evolution Hopper EV01000

Product Manual

Version 1.1 / Oct 2007



A.u.S. Spielgeräte GesmbH
Scheydgasse 48 A-1210 Wien
Tel. +43-1-271 66 00 Fax.+43-1-271 66 00 75
E-mail: verkauf@aus.at
<http://www.aus.at>
Öffnungszeiten: Mo-Fr. 9-18 Uhr

Revision History

| Revision | Date | Comment | By |
|-----------------|--------------|---|-----------|
| 0.1 | 5 Sept 2005 | Initial Release | R.T. |
| 0.2 | 12 Sept 2005 | Added hopper application information (chapter 7) Renumbered chapters | R.T. |
| 0.3 | 18 Sept 2005 | Added section 6.8.4 | R.T. |
| 1.0 | 1 Nov 2005 | Part-numbers, spelling | E.S. |
| 1.1 | 17 Okt 2007 | New Exploded views. Table belt part-numbers | E.S. |

This manual is intended only to assist the reader in the use of this product and therefore the manufacturer shall not be held liable for any loss or damage whatsoever arising from the use of any information or particulars in, or any omission from this manual or any incorrect use of the product.

Design and specifications are subject to change without notice.

Wijzigingen in ontwerp en technische gegevens voorbehouden, zonder kennisgeving.

La conception et les spécifications sont modifiables sans préavis.

El diseño y especificaciones están sujetos a cambios sin previo aviso.

WARNING!

Failure to observe the interface requirements specified in this technical manual may result in miscounts, damage to the electronics and the motor of the hopper or create unacceptable voltage drops, affecting other units depending on the same power supply.

Contents

| | |
|--|----|
| 1. Introduction | 6 |
| 2. Safety Note | 6 |
| 3. General Description | 6 |
| 3.1 Description | 6 |
| 3.2 Options | 7 |
| 3.2.1 Track options | 7 |
| 3.2.2 Connector position | 7 |
| 3.2 Level Sensing | 7 |
| 3.3 Connectors | 7 |
| 3.4 Coin Sizes | 8 |
| 3.5 Base-plate | 8 |
| 4. Installation | 9 |
| 4.1 Baseplate | 9 |
| 4.2 Safety | 9 |
| 5. Mechanical Description | 10 |
| 5.1 General | 10 |
| 5.2 Removal of the Electronics and Opto Sensor Board | 10 |
| 5.3 Track guard Removal and Refitting | 10 |
| 6. Electronic Description | 11 |
| 6.1 General Electronic Description | 11 |
| 6.2 Operating Mode Selection | 11 |
| 6.2.1 MODE 0 DIRECT SWITCHING | 11 |
| 6.2.2 MODE 1 LOGIC CONTROL | 11 |
| 6.2.3 MODE 2 COIN COUNTING | 11 |
| 6.2.4 RESET FUNCTION | 12 |
| 6.3 Optical Sensors | 12 |
| 6.4 Optical Security Feature | 12 |
| 6.5 Motor Operation | 12 |
| 6.6 Motor Current Limit | 12 |
| 6.7 Coins With Holes | 13 |
| 6.8 High Security Exit Window | 13 |
| 6.8.1 Description | 13 |
| 6.8.2 Security | 13 |
| 6.8.3 Opto test | 13 |
| 6.8.4 Dirty opto | 13 |
| 7. Hopper Application | 14 |
| 7.1 Power Supply | 14 |
| 7.2 Suggested hopper connection | 14 |
| 7.3 Hopper control | 15 |
| 7.3.1 Mode 0 | 15 |
| 7.3.2 Mode 1 | 15 |
| 7.3.3 Mode 2 | 15 |
| 7.3.4 Security Output | 15 |
| 7.3.5 Coin Exit Output | 15 |
| 7.3.6 Low Level and High (Top) Level output | 15 |
| 8. Technical Specifications | 16 |
| 8.1 Coin Sizes | 16 |
| 8.2 Capacity | 16 |
| 8.3 Connector | 16 |
| 8.4 Electrical Interface | 16 |
| 8.5 Logic Inputs | 17 |
| 8.6 Logic Outputs | 17 |
| 8.7 Interface Options | 17 |
| 8.8 Pay-out Rate | 17 |
| 8.9 EMC approval | 17 |
| 8.10 Environment | 17 |
| 9. Dimensions | 18 |
| 10. Exploded Views | 20 |

Tables

Table 1: Hopper Capacity for Some Popular Coins 6
Table 2: Coin Size vs. Track Type 8
Table 3: Mode Selection Input Logic 11
Table 4: Coin Size vs. Track type 16
Table 5: Electrical Interface 16

Figures

Figure 1: Connector locations 7
Figure 2: Connector pin-out 7
Figure 3: Hopper connection diagram 14
Figure 4: Connector pinout 16
Figure 5: Logic inputs 17
Figure 6: Logic outputs 17
Figure 7: Hopper dimensions 18
Figure 8: Base plate dimensions 19
Figure 9: 21.01 – 30.00 mm series 20
Figure 10: 19.00–26.40 mm series 21
Figure 11: 16.25 – 20.90 mm series 22

1. Introduction

Easier serviceability and higher speed are the two key elements for developing this product. This product is compatible with most other belt driven hoppers in the market.

2. Safety Note

To meet the requirements for EN 60950 the equipment must be installed according to the following requirements: A 3A fuse must protect the equipment.

The equipment must be supplied from a SELV limited power source.

The equipment must be installed in an enclosure but positioned so that it is external to any fire enclosure area within the main enclosure.

3. General Description

3.1 Description

The Evolution Hopper is an universal intelligent large capacity coin and token dispenser ideal for a wide range of applications including Gaming, Vending and Transportation systems.

The Evolution hopper will handle most coins in the range 16.25mm to 30mm diameter and 1.25mm-3.5mm thick, giving the following approximate capacities:

$$\text{Capacity} = \text{Hopper volume} / \text{Coin volume} = \frac{1,200,000}{\frac{\pi \times D^2}{4} \times T}$$

D = Coin diameter (mm)
T = Coin thickness (mm)

| Diameter (mm) | Thickness (mm) | Coin type | Approx. capacity |
|---------------|----------------|------------|------------------|
| 25.75 | 2.20 | 2 Euro | 1000 |
| 23.25 | 2.35 | 1 Euro | 1200 |
| 24.25 | 2.40 | 0.50 Euro | 1100 |
| 24.25 | 1.75 | US quarter | 1500 |

Table 1: Hopper capacity for some popular coins

The standard version of the Evolution Hopper can handle coins between 21.01 and 30.00 mm.

A Euro coin track is available for all Euro coins (between 19.00 – 26.40 mm).

A small coin track is available for smaller coins between 16.25 and 20.90 mm (optional).

A large coin track is in preparation for coins of 31 mm (optional).

The pay-out speed depends on the coin size and the amount of coins in the hopper but the average speed is approximately 4 coins per second.

Precise pay-out is ensured through optical sensing and verifying of coin dispensing with an electronic security signal which alerts against coin jams, failed sensors and a bad power supply.

LED indicators are provided for easy visual checking of power supply, security status and coin sensors.

The standard interface can be set in 3 different modes:

Mode0: Hopper starts paying out as soon as the power is supplied

Mode1: Hopper is started by a logic control line (active low).

Mode2: Hopper pays a coin for each start pulse it receives.

3.2 Options

3.2.1 Track options

The standard Evolution Hopper handles coins in the diameter range of 21.01 – 30.00 mm, An Euro coin track is available for all Euro coins (between 19.00 – 26.40 mm). The small coin Evolution Hopper handles coins in the diameter range of 16.25 mm 20.90 mm.

3.2.2 Connector position

The 12pin connector can be in one of two positions, either on the opposite side of the coin exit, known as the Rear (R) position, or on the same side as the coin exit, known as the Front (F) position. Standard for the Evolution hopper is the connector on the adjacent position. The user can easily change this on an Evolution Hopper by loosening two screws on the bottom section, taking out this part and then placing the cable with the connector at the opposite side.

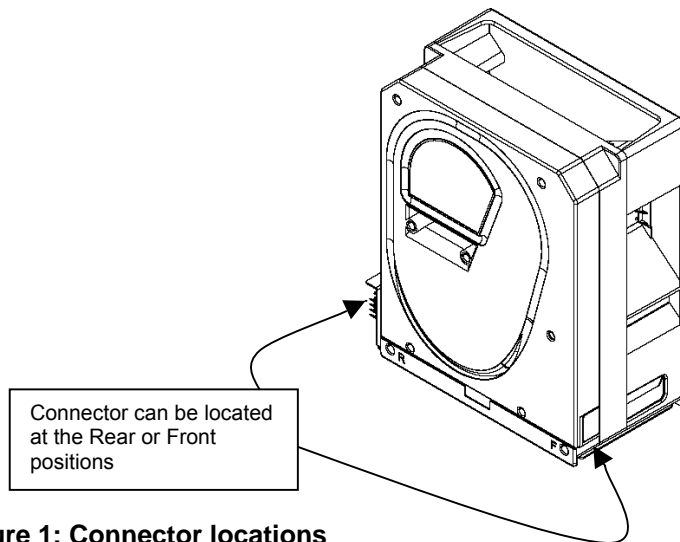

Figure 1: Connector locations

3.2 Level Sensing

All Evolution Hoppers are standard supplied with a low level and high level sensing function.

3.3 Connectors

Evolution Hopper is only available with the Industry compatible connector. (Compatible with the green CINCH connector)



| Pin | Description |
|-----|--------------------------------|
| 1 | Motor Supply 0 Vdc |
| 2 | Logic Supply 0 Vdc |
| 3 | Coin Exit Output |
| 4 | IN1 |
| 5 | Security Output |
| 6 | High or Top level Sense Output |
| 7 | Low Level Sense Output |
| 8 | IN2 |
| 9 | Motor Supply 24Vdc |
| 10 | Logic Supply 12 - 24Vdc |
| 11 | Coin Exit Output |
| 12 | IN3 |

Figure 2: Connector pin-out

3.4 Coin Sizes

| Track type | Coin sizes | Color | Part. nr. |
|--|-----------------------------------|--------|-----------|
| Standard (€2, €1, €0.50, €0.20) | 21.01 – 30.00 mm x 1.25 – 3.30 mm | Red | EV0050 |
| Euro (€2, €1, €0.50, €0.20, €0.10, €0.05) | 19.00 – 26.40 mm x 1.50 – 2.50 mm | Yellow | EV0050-3 |
| Euro small (€0.10, €0.05, €0.02, €0.01) | 16.25 – 20.90 mm x 1.00 – 3.10 mm | Green | EV0050-4 |

Table 2: Coin size Vs Track type

3.5 Base-plate

The base-plate offers the easy slide in and out function with a pre-fitted connector that can simply be removed for fitting it in a cable-harness.

The base-plate is standard supplied with the Evolution Hopper.

See Figure 8: Base plate dimensions.

4. Installation

Important: Shut-off the power from the host machine until any installation work is completed.

4.1 Baseplate

1. Secure the base-plate in position using the six fixing holes. The hole positions are shown in Figure 8: Base plate dimensions.
2. Wire up the base-plate connector to the host machine see Figure 2: Connector pin-out for connector details and for interfacing recommendations.

NOTE: The wire to be used should have a maximum length of 3 metres and must be capable of handling the maximum Currents and Voltages specified in Table 5: Electrical Interface.

3. Slide the hopper into the base-plate and ensure that the two halves of the connector are securely mated.
4. Turn on the power.

4.2 Safety

1. Do not put a hand into the hopper while the motor is running.
2. Static. It is possible for coins paid out to have a static charge on them.
3. Coins should be discharged to earth before being presented to the user.

5. Mechanical Description

5.1 General

The hopper is mounted in a machine via the base plate.

Electrical connection to the hopper is made via the 12-pin socket on the base plate which mates with the corresponding plug on the hopper body. Coins are stored in the cash box section of the hopper and fed onto the elevator belt via a passage in the centre plate. The cut-out in the centre plate has been designed to regulate the flow of coins onto the belt. The stirrer agitates the coins in the coin box in order to minimise the occurrence of bridging. The elevator belt is driven by a motor, gearbox, and idler gear. Coins are picked up at the bottom of the belt and carried up to the exit window. Optical sensors in the exit window detect the coins as they roll out of the hopper.

A cable connects the main control board to the 12 way socket and carries all power supplies and control signals.

5.2 Removal of the Electronics and Opto Sensor Board.

All the electronics and sensors are placed on one board located behind the exit door at the side of the hopper. Slide the yellow button to the opposite position and remove the exit door where the electronics are mounted. Taking out the board for cleaning the optic sensors is a matter of seconds.

Warning: be careful by re-inserting the board back in the hopper not to damage the cable located at the back of the board!

5.3 Track guard Removal and Refitting

Firstly, locate cut away slots in Centre Plate and End Plate at the base of the track guard opposite the PCB. Push track guard up to reveal a gap between body moulding and the guard. Insert broad flat bladed screwdriver or equivalent into gap and gently lever out the guard until the leading edge is above the outside edge of the body mouldings. Now slide the guard down towards the cut out and gradually withdraw it. Slide back the track guard to refit.

6. Electronic Description

6.1 General Electronic Description

Operation of the hopper is controlled by an 8-bit microprocessor. The firmware allows the choice of 3 different operating modes. It also provides PWM motor control drive via a MOSFET bridge and an optical pay-out detection output. Separate power supplies are recommended for the motor supply input and the logic supply input.

6.2 Operating Mode Selection

Three modes of operation are available, selected via inputs IN1 and IN2 (pins 4 and 8 of the 12 way connector). Input signals may be controlled by the host machine, or may be hardwired. Additionally, input IN3 (pin 12) is the logic control line, used in modes 1 and 2. These inputs are passive pull-up and active pull-down.

The signals therefore default to logic "1" if left open circuit.

NOTE: It is strongly recommended that if these inputs are to be controlled by the host machine, then open collector NPN transistors, referenced to logic OV (connector pin 2) be used to set the input levels to IN1, IN2 and IN3.

The exception is the RESET mode, which can be applied at any time (with instantaneous effect). Mode selection is determined at power up.

The hopper allows a 100ms timeout after power up, then reads the inputs IN1 and IN2. The hopper will remain in the selected mode until the power is removed, i.e., any further changes in the levels at IN1 and IN2 will be ignored. See Table 3: Mode selection input logic.

| Mode | IN1 | IN2 |
|-------|-----|-----|
| 0 | 1 | 1 |
| 1 | 0 | 0 |
| 2 | 1 | 0 |
| Reset | 0 | 1 |

Table 3: Mode selection input logic

6.2.1 MODE 0 DIRECT SWITCHING

This is the default operating Mode, and is selected when all of the input selectors are left open circuit. When the 24V line is established, the motor starts in the forward direction and when the 24V power line is removed, the motor is braked.

6.2.2 MODE 1 LOGIC CONTROL

In this mode the logic and 24V power supplies can be permanently connected and motor function is determined via a logic level on the IN3 input.

When IN1 (pin 4) and IN2 (pin 8) are pulled down to OV at power up, mode 1 is selected. The operation of the motor is now controlled via a logic signal on IN3 (pin 12). With the 24V supply present, a low level on IN3 starts the motor and a high level on IN3 brakes the motor.

6.2.3 MODE 2 COIN COUNTING

In this mode, the hopper will pay out a coin for every pulse it receives on input IN3.

Mode 2 is selected by setting IN1 (pin 4) high and IN2 (pin 8) low at power up. Once selected, the processor continually scans input IN3. When a pulse is detected on IN3, an internal register is incremented. When a coin is paid out, it is detected and the register is decremented.

The motor is started when the internal coin register is non-zero and is stopped when it returns to zero. The maximum count for the coin register is 4095 coins. Should the 24V line fail at any point, the motor is braked. When the 24V line reappears, the pay-out of coins continues until the coin register returns to zero. Coin counting on IN3 can take place while coins are being paid out. A pulse is defined as a falling edge followed by a rising edge. Pulse edges may be no closer than 5ms. This is so that the processor has adequate time to poll the IN3 pin and debounce. This represents a maximum pulse rate of 100Hz. There is no lower limit. The waveform duty cycle is unimportant.

At power up in mode 2, IN3 is high. The first falling edge will be recognised as the first pulse and the hopper motor will start running.

Pulsing on IN3 should not commence earlier than 130ms after the logic supply has been established. This will allow for the power up timeout of 100ms and further processing time prior to running the main program.

6.2.4 RESET FUNCTION

In this mode the Hopper is reset, i.e. processor reset and motor drive disabled. This function is provided as added security enabling the host machine to immediately stop the Hopper irrespective of its mode of operation.

Whilst in this mode connecting IN3 (pin 12) to ground turns the exit window sensor off in order to test it is operative. Confirmation would be given as a signal output on pin 3 and 11 of the 12 pin connector.

6.3 Optical Sensors

Optical sensors are fitted on the optic board in the exit window to detect coin pay-out.

A debounced coin output is available on pin 3 and pin 11. When no coins are present at the exit window, the optical sensors are clear, the output transistors are open circuit, and the LED indicator is off. Coins passing the optical sensors obstruct the light path causing the output transistors to pull down to OV and the GREEN LED SENSOR indicator switches on.

6.4 Optical Security Feature

The output of the optical sensor is monitored by the microprocessor and if the sensor remains obstructed for more than one second, the motor will be braked and will remain off until either the sensor is cleared or power down takes place. This action will result if a coin jams in the exit window or if the optical sensor fails which could be checked by toggling IN3 in Reset Mode. If the security feature is operational, the security output on output pin 5 and the LED SECURITY indicator will be switched off.

The optical security feature operates identically in all 3 Modes.

6.5 Motor Operation

The DC motor is controlled by the processor via a transistor bridge. The motor will run provided that one of the sets of conditions shown below is met. If any single condition fails then the motor is braked and remains so until all conditions be true, or a power down occurs.

Mode 0 Motor Start Conditions:

- Security feature true
- 24V line true.

Mode 1 Motor Start Conditions:

- Security feature true
- 24V line true
- IN3 input low.

Mode 2 Motor Start Conditions:

- Security line true
- 24V line true
- internal coin count nonzero.

When braking is initiated for whatever reason, 50ms braking is carried out even if the fault condition recovers before that time. This guarantees that the motor is stationary when the bridge drivers change state, so that no excess current flows in the motor windings.

6.6 Motor Current Limit

The motor current is monitored by the processor. When the motor initially starts, the current is build up gradually using PWM-current control. This reduces the high initial surge currents that occur in non-current controlled motor driver circuits.

If the current rises above a pre-set value, then a jam is deemed to have occurred. The motor is braked for 50ms then reversed for 150ms. After a further 50ms braking, the motor is started in the forward direction again.

The current is tested after 100ms and if the jam has not been cleared the reversing cycle will be repeated. This action will continue until the jam has cleared. This reversing action is effective in clearing soft jams.

One further action is to test the current in the reverse direction during the final 50ms of the reversing cycle. If during that time period an over current is detected, then the motor will be braked for 50ms and then disabled for 1 second. This action limits the duty cycle sufficiently in the case where a jam is solid in order to prevent motor damage.

6.7 Coins With Holes

The Evolution Hopper will work with most coins/tokens with holes depending on the size of the hole in relation to the diameter. To make sure whether your desired coin is qualified within the specifications of the Evolution Hopper please contact the technical department

The exit window has been designed so that more coins with holes will be counted correctly.

No adjustments are necessary to cope with standard and small coins.

6.8 High Security Exit Window

6.8.1 Description

The payout window uses optics consisting of an IR-Led transmitting a beam that is reflected by a prism in an U-shaped form and received back on an IR-receiver.

The intensity of the IR-pulse is minimized, so that the (somewhat transparent) plastic coins as well as highly reflective coins are detected as optimal as possible.

The intensity of the IR-pulse is adjusted dynamically to a higher level if the opto-sensor becomes dirty.

6.8.2 Security

- The IR-led transmits pulses with a random duty-cycle between 16 – 20%.
- When light is received when no IR-pulse is being transmitted, (exit window is 'blinded' by external light), the hopper will stop immediately if it was running, the security led will go off and the security output will go high (error state).
- If the opto-sensor is interrupted for more than 1 second, the hopper will also stop and go into error state. If the coin exit becomes unblocked again and the hopper start conditions are still met, the hopper will resume running.

6.8.3 Opto test

By holding the hopper in reset and toggling the IN3 line, the optics can be checked for a blockage prior to paying out.

During Reset, a High on IN3 will cause a low on "Output 1" and "Output 2". Alternately a Low on IN3 will cause a high on "Output 1" and "Output 2".

NOTE: *This is only true if the optics are NOT blocked.*

6.8.4 Dirty opto

If the opto becomes dirty, the red led on the board starts flashing, indicating that it needs to be cleaned. The opto-sensor remains operating reliably. If the opto-sensor becomes even more dirty, the security output becomes high. The opto-sensor remains operational.

7. Hopper Application

7.1 Power Supply

For ease of use and maximum noise suppression, the 0 volt logic line (pin 2) and the motor 0 volt line (pin 1) are not commoned inside the hopper. This means the outputs from the hopper (Coin Exit and Security) are noise free.

7.2 Suggested hopper connection

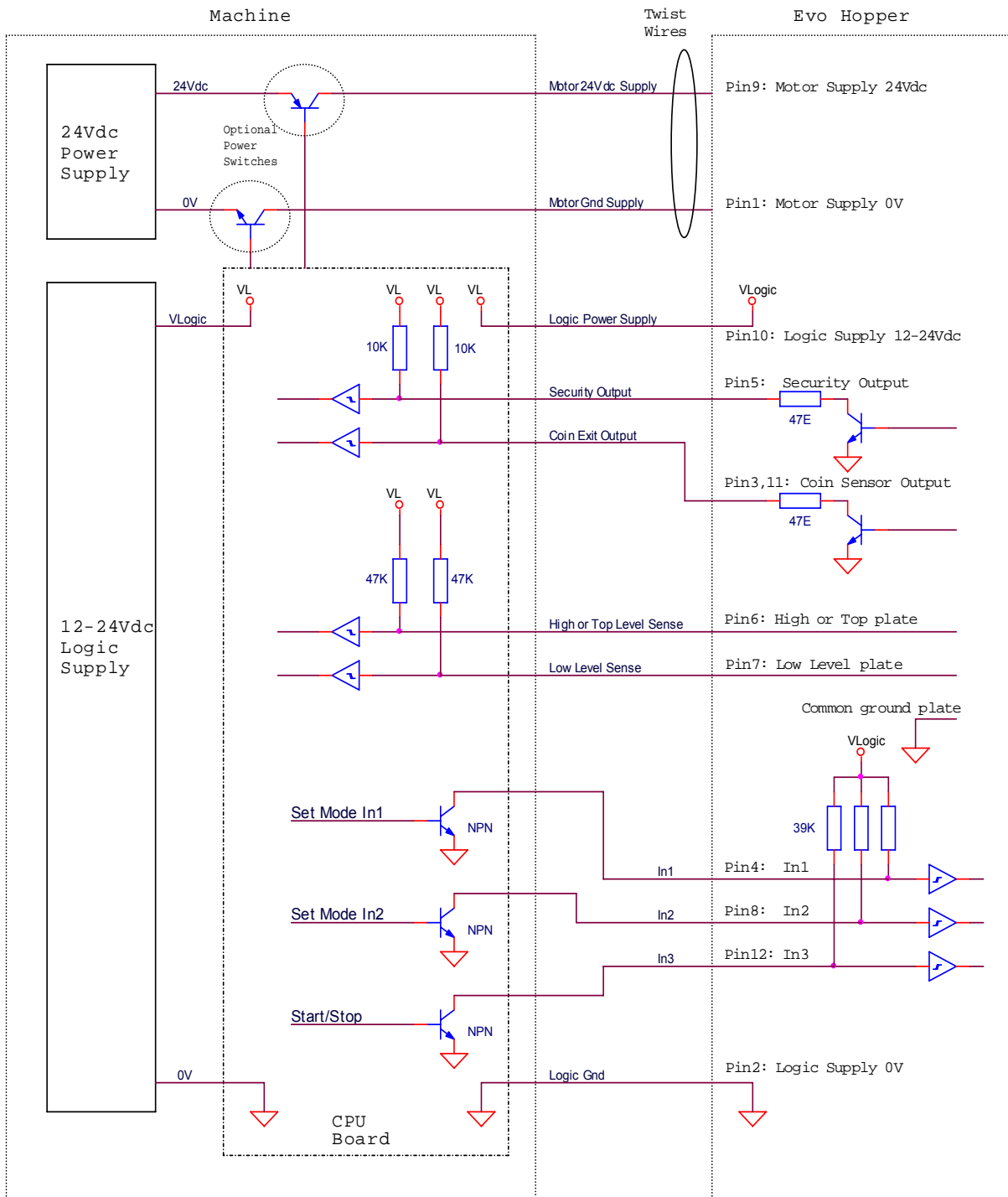

Figure 3: Hopper connection diagram

The power switches are optional. These switches can be used for additional security regarding hopper payout. By powering the hopper first with the logic supply, the presence and hopper status can be checked by testing the security and coin exit outputs. If the hopper is Ok, the power switches may be activated to start hopper payout.

7.3 Hopper control

As soon as the hopper logic power supply is present, the hopper will set the operating mode by reading its In1 and In2 inputs. See Table 3: Mode selection input logic for all modes.

The mode can be set by hardwiring In1 and In2 or by logic control by the machine.

Controlling the In1 and In2 inputs by the machine gives the possibility to put the hopper temporarily in RESET mode to check the opto-sensors and coin exit output.

As long as the hopper logic power is present, the hopper mode can not be changed, except for the RESET mode. Entering RESET mode can be done always. After leaving the RESET mode by changing the In1 and In2 level again, the hopper performs an internal reset, and the new operating mode is determined from the In1 and In2 levels.

7.3.1 Mode 0

If the hopper is set in mode 0, the hopper is started by applying Vmotor to the hopper. This can be done by switching the 24V power line, or by switching the 0V line or both. The hopper is braked as soon as Vmotor is switched off. Note that in order to prevent any over-payouts, the hopper should be braked at the first (falling) edge of the coin exit output pulse.

7.3.2 Mode 1

In mode 1 the hopper is started by pulling the In3 line low to ground. The hopper is braked as soon as the In3 line is pulled up again to Vlogic. Note that in order to prevent any over-payouts, the hopper should be braked at the first (falling) edge of the coin exit output pulse.

7.3.3 Mode 2

In mode 3, for each active low pulse transmitted on In3, a coin is paid. The hopper will stop automatically after the last start pulse.

7.3.4 Security Output

During normal hopper operation this output is active low. The security output will be pulled up to Vlogic (high) if the opto-sensor is not working correctly (dirty, fraud or defect).

This output can also be used to check the presence of the hopper (output should be low then).

7.3.5 Coin Exit Output

As soon as a coin enters the opto exit window, the coin exit will go active low (after a small digital filter 5ms) and go up again (pulled up) when the coin leaves the coin exit window.

If a coin blocks the opto-sensor for more than 1 second, the hopper motor is braked and started again as soon as the opto is not blocked anymore.

If the opto-sensor has become too dirty, the coin exit will remain low.

7.3.6 Low Level and High (Top) Level output

These outputs are directly attached to the plate sensors of the Evolution Hopper. They must be pulled up by the machine. When the hopper is filled with coins these plates are shorted to the ground plate via the coins. During payout the coins will move over the plates causing changing signals on the outputs. The best moment to check the coin level outputs is when the hopper is not paying out.

8. Technical Specifications

8.1 Coin Sizes

| Track type | Coin sizes | Color | Part. nr. |
|--|-----------------------------------|--------|-----------|
| Standard (€2, €1, €0.50, €0.20) | 21.01 – 30.00 mm x 1.25 – 3.30 mm | Red | EV0050 |
| Euro (€2, €1, €0.50, €0.20, €0.10, €0.05) | 19.00 – 26.40 mm x 1.50 – 2.50 mm | Yellow | EV0050-3 |
| Euro small (€0.10, €0.05, €0.02, €0.01) | 16.25 – 20.90 mm x 1.00 – 3.10 mm | Green | EV0050-4 |

Table 4: Coin size vs Track type

8.2 Capacity

$$\text{Capacity} = \text{Hopper volume} / \text{Coin volume} = \frac{1,200,000}{\frac{\pi \times D^2}{4} \times TK}$$

D = Coin diameter (mm)
T = Coin thickness (mm)

8.3 Connector



| Pin | Description |
|-----|--------------------------------|
| 1 | Motor Supply 0 Vdc |
| 2 | Logic Supply 0 Vdc |
| 3 | Coin Exit Output |
| 4 | IN1 |
| 5 | Security Output |
| 6 | High or Top level Sense Output |
| 7 | Low level Sense Output |
| 8 | IN2 |
| 9 | Motor Supply 24Vdc |
| 10 | Logic Supply 12 - 24Vdc |
| 11 | Coin Exit Output |
| 12 | IN3 |

Figure 4: Connector pinout

8.4 Electrical Interface

| Electrical Interface | Parallel | Serial |
|----------------------|----------|--------|
| Voltage: nominal | 24 VDC | 24 VDC |
| minimum | 18 VDC | 20 VDC |
| maximum | 26 VDC | 26 VDC |
| Current (typical): | | |
| idle | 40 mA | 40 mA |
| empty | 0.2 A | 0.2 A |
| full | 0.7 A | 0.7 A |
| surge | 2.5 A | 2.5 A |

Table 5: Electrical Interface

8.5 Logic Inputs

| Description | Value (Vin) |
|---------------------------|-------------|
| Recommended logic 0 input | <= 0.6V |
| Recommended logic 1 input | >= 2.6V |

Figure 5: Logic inputs

8.6 Logic Outputs

| Description | Value |
|-------------------------------|----------------|
| Output level 0 | <= 0.3 at 50mA |
| Max sink current | 100mA |
| Max pull-up voltage | 30Vdc |
| Coin exit typical pulse width | 70 – 120ms |

Figure 6: Logic outputs

8.7 Interface Options

- Standard Parallel (EV01000) series
- ccTalk Non Encrypted version (EV02000) series
- ccTalk Encrypted version (EV03000) series
- ccTalk MC Non Encrypted version (EV04000) series

8.8 Pay-out Rate

appr. 4 coins per sec.

8.9 EMC approval

- EN 55014-1 (2000) + A1 (2001) + A2 (2002): Electromagnetic Compatibility: Requirements for household appliances, electric tools and similar apparatus - Part 1: Emission.
- EN 55014-2 (1997) + A1 (2001): Electromagnetic Compatibility - Requirements for household appliances, electric tools and similar apparatus - Part 2: Immunity – Product family standard.
- EN 61000-3-2 (2000): Electromagnetic compatibility - Part 3-2: Limits - Limits for Harmonic current emissions (equipment input current < 16A per phase).
- EN 61000-3-3 (1995) + A1 (2001): Electromagnetic compatibility - Part 3: Limits - Section 3: Limitation of voltage fluctuations and flicker in low- voltage supply systems for equipment with rated current < 16A.

FCC approval:

- 47CFR15: Radio Frequency Devices

8.10 Environment

| Description | Value |
|-----------------------|----------------------------------|
| Operating temperature | 0 to 60°C |
| Storage temperature | -20 to 60°C |
| Life | Up to 3 million coins |
| Mounting | ±3° of vertical in any direction |

Note: *DO NOT use the hopper in an explosive atmosphere*

9. Dimensions

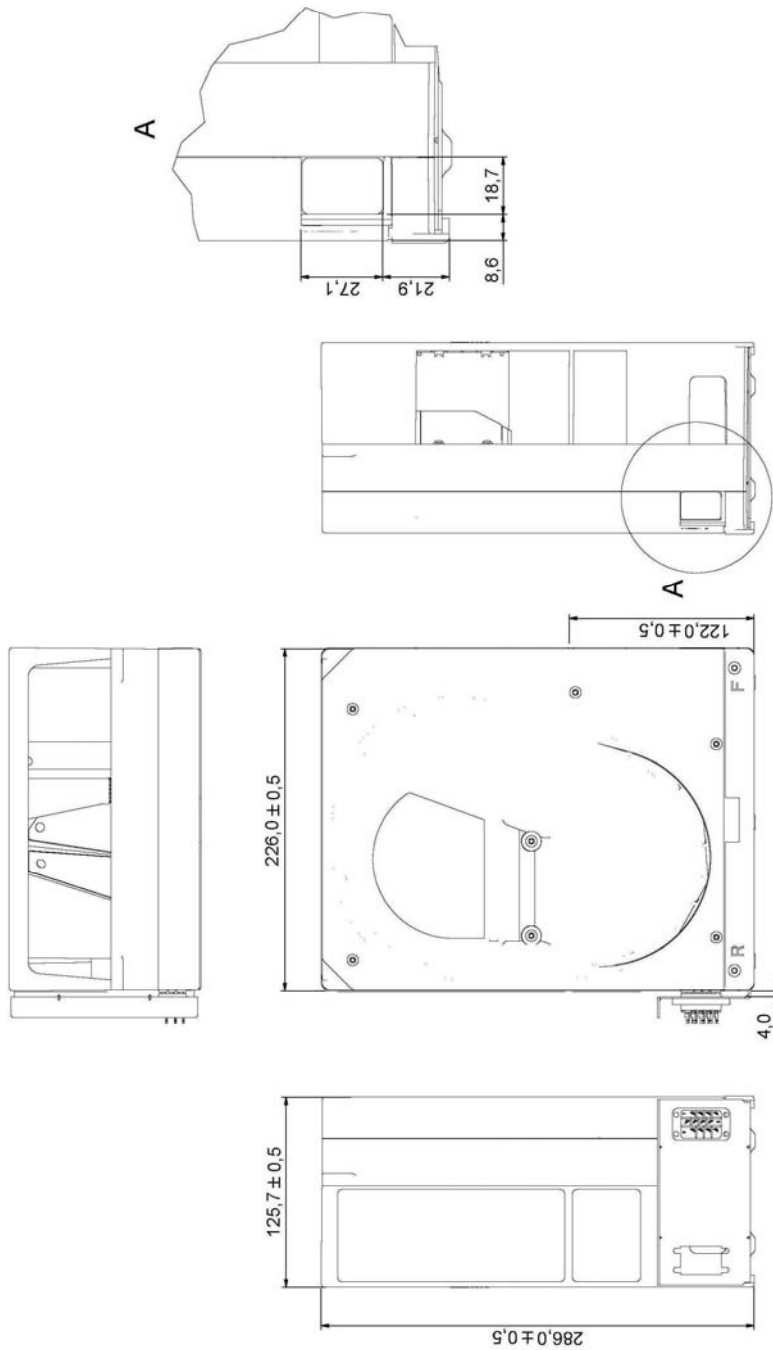

Figure 7: Hopper dimensions

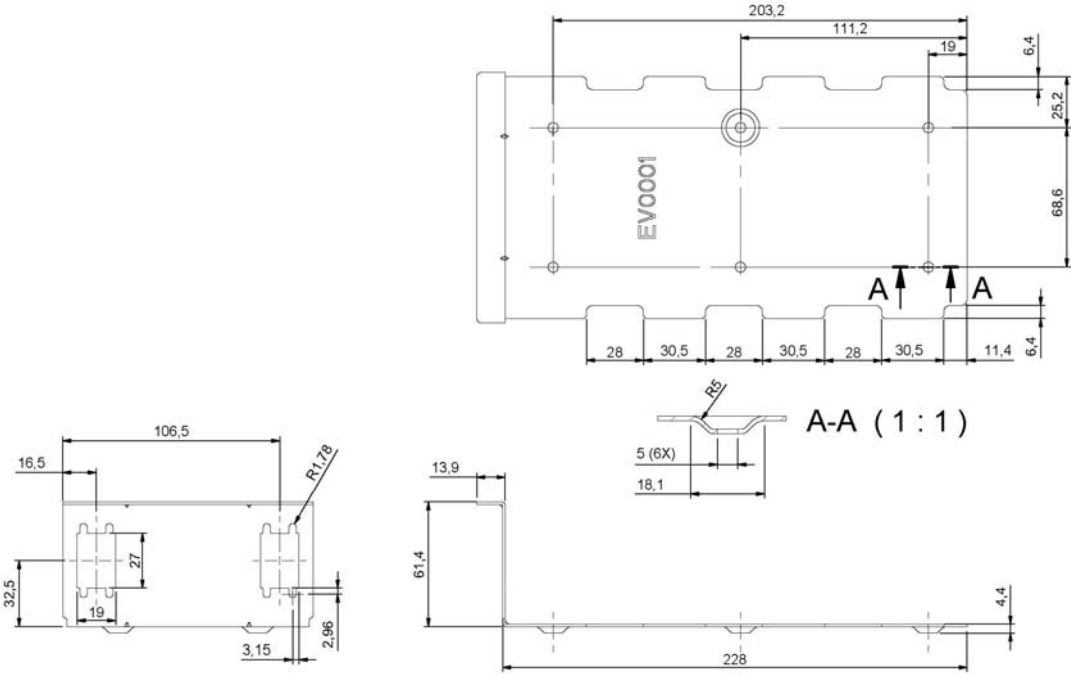

Figure 8: Base plate dimensions

10. Exploded Views

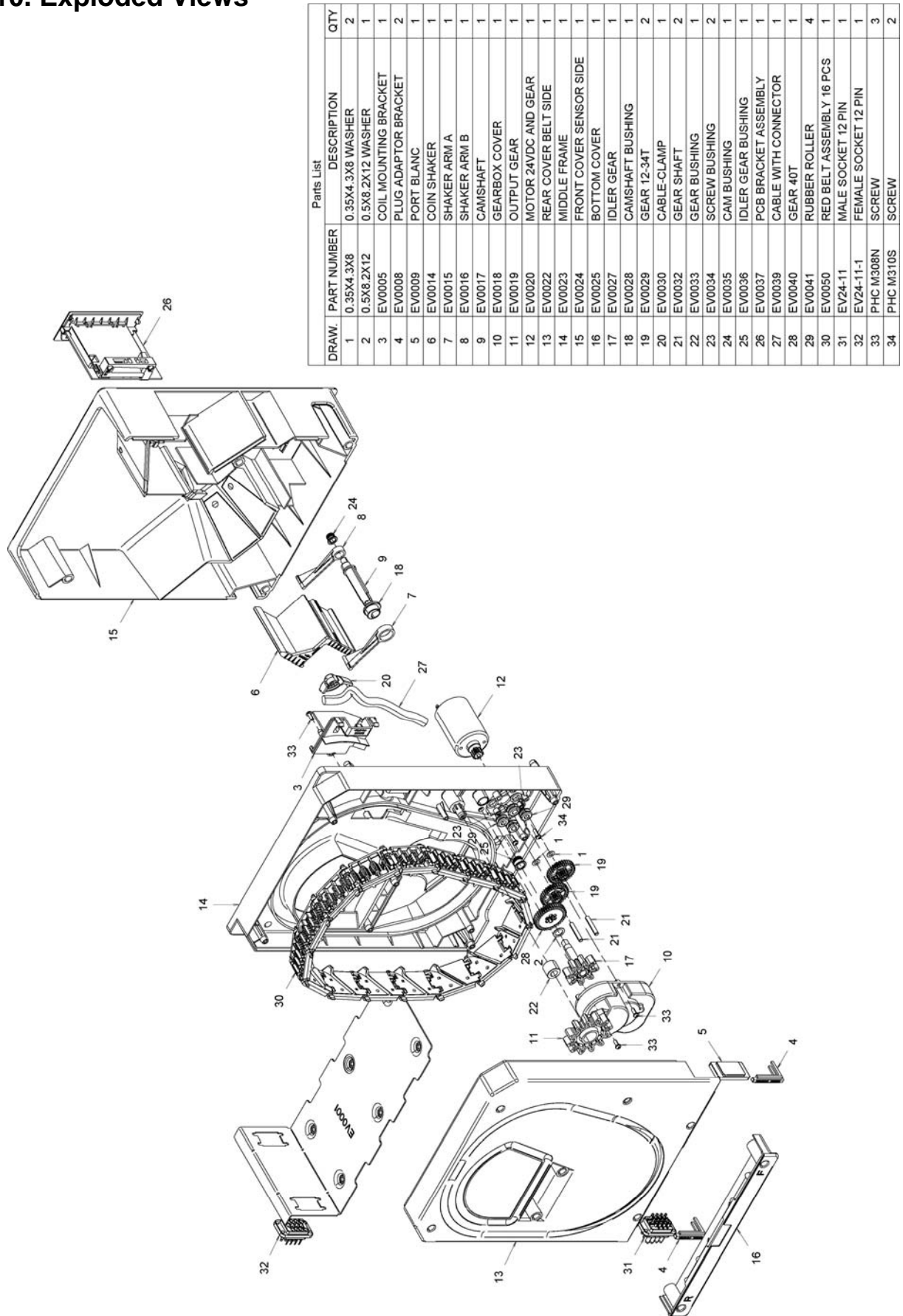

Figure 9: 21.01 – 30.00 mm series

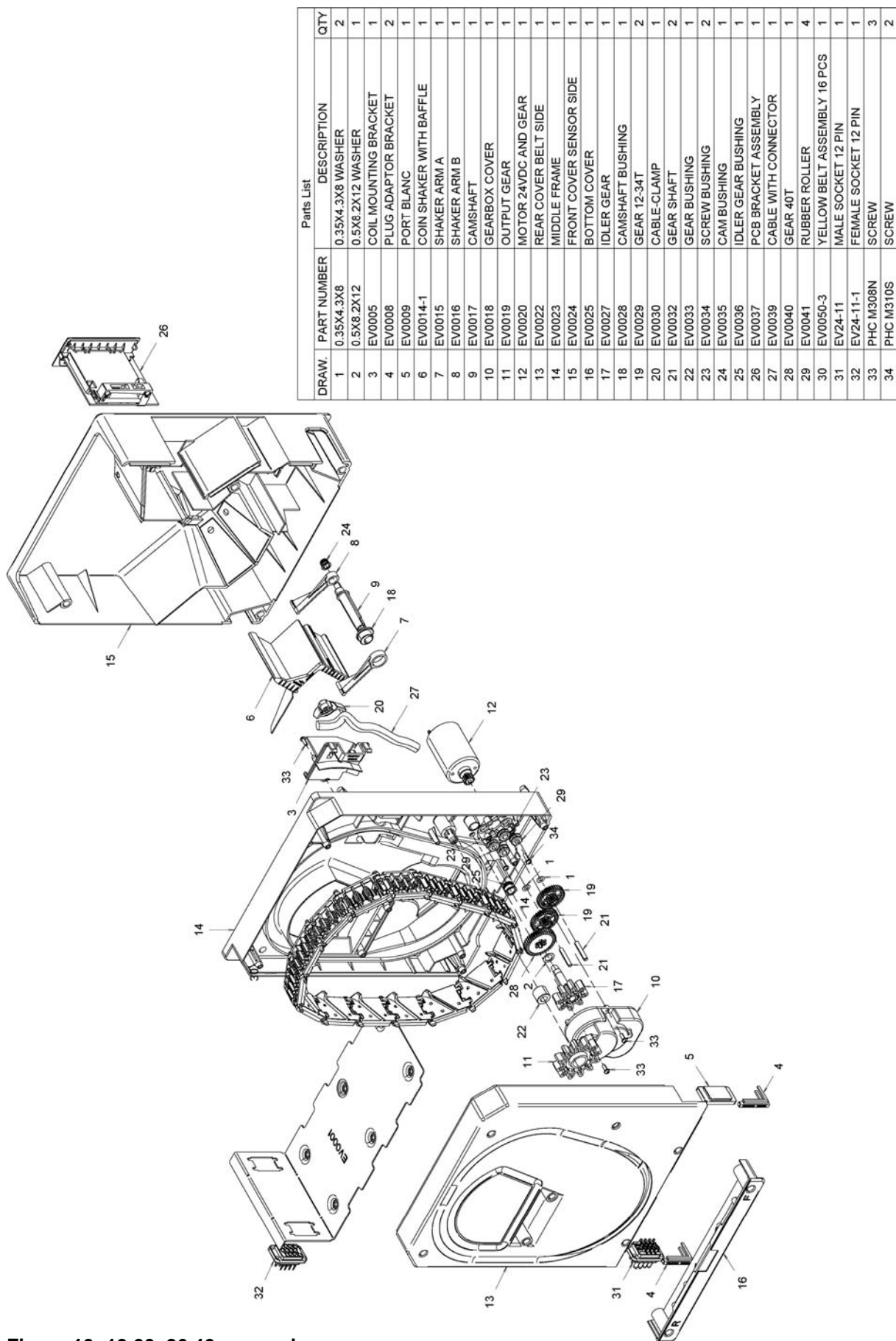
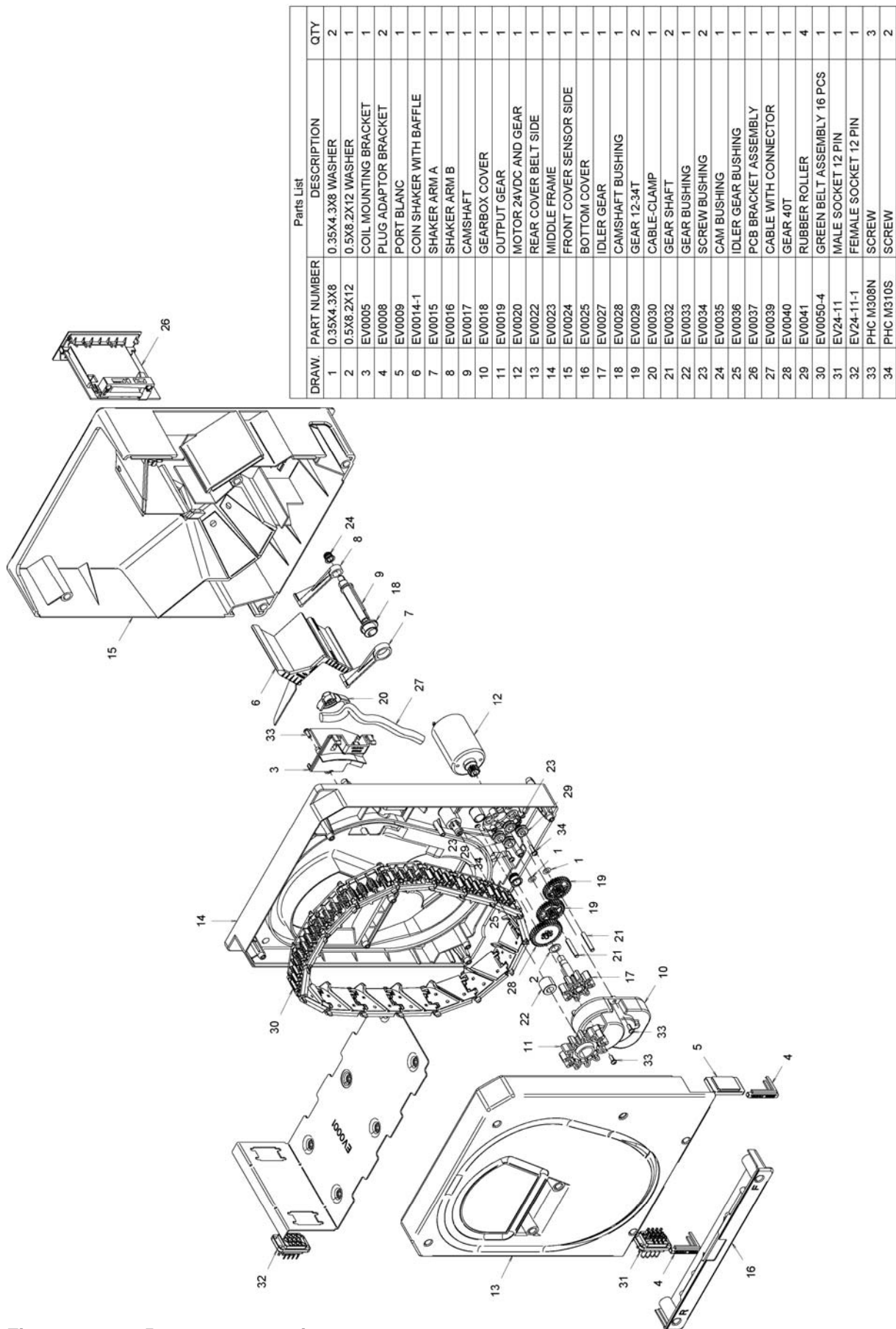

Figure 10: 19.00–26.40 mm series



| Parts List | | | |
|------------|-------------|----------------------------|-----|
| DRAW. | PART NUMBER | DESCRIPTION | QTY |
| 1 | 0.35X4.3X8 | 0.35X4.3X8 WASHER | 2 |
| 2 | 0.5X8.2X12 | 0.5X8.2X12 WASHER | 1 |
| 3 | EV0005 | COIL MOUNTING BRACKET | 1 |
| 4 | EV0008 | PLUG ADAPTOR BRACKET | 2 |
| 5 | EV0009 | PORT BLANC | 1 |
| 6 | EV0014-1 | COIN SHAKER WITH BAFFLE | 1 |
| 7 | EV0015 | SHAKER ARM A | 1 |
| 8 | EV0016 | SHAKER ARM B | 1 |
| 9 | EV0017 | CAMSHAFT | 1 |
| 10 | EV0018 | GEARBOX COVER | 1 |
| 11 | EV0019 | OUTPUT GEAR | 1 |
| 12 | EV0020 | MOTOR 24VDC AND GEAR | 1 |
| 13 | EV0022 | REAR COVER BELT SIDE | 1 |
| 14 | EV0023 | MIDDLE FRAME | 1 |
| 15 | EV0024 | FRONT COVER SENSOR SIDE | 1 |
| 16 | EV0025 | BOTTOM COVER | 1 |
| 17 | EV0027 | IDLER GEAR | 1 |
| 18 | EV0028 | CAMSHAFT BUSHING | 1 |
| 19 | EV0029 | GEAR 12-34T | 2 |
| 20 | EV0030 | CABLE-CLAMP | 1 |
| 21 | EV0032 | GEAR SHAFT | 2 |
| 22 | EV0033 | GEAR BUSHING | 1 |
| 23 | EV0034 | SCREW BUSHING | 2 |
| 24 | EV0035 | CAM BUSHING | 1 |
| 25 | EV0036 | IDLER GEAR BUSHING | 1 |
| 26 | EV0037 | PCB BRACKET ASSEMBLY | 1 |
| 27 | EV0039 | CABLE WITH CONNECTOR | 1 |
| 28 | EV0040 | GEAR 40T | 1 |
| 29 | EV0041 | RUBBER ROLLER | 4 |
| 30 | EV0050-4 | GREEN BELT ASSEMBLY 16 PCS | 1 |
| 31 | EV24-11 | MALE SOCKET 12 PIN | 1 |
| 32 | EV24-11-1 | FEMALE SOCKET 12 PIN | 1 |
| 33 | PHC M308N | SCREW | 3 |
| 34 | PHC M310S | SCREW | 2 |

Figure 11: 16.25 – 20.90 mm series